



SEAL·A·TRON

Shrink Packaging Equipment

SHRINK TECH SYSTEMS



PREMIUM MACHINERY
at a Reasonable Price!



MODEL
S-1722HK

**SEMI-AUTOMATIC
L-BAR SEALER**

Seal Bar Dimensions: 17"W x 22"L x 8"H

Standard Features:

- Hot Knife L-Bar Sealer
- Dual Mag-LOK Extra Strong Magnets
- Lightly Balanced Seal Head Pivot
- EZ-Perf Venting Pin Perf
- Product Discharge Conveyor with Soft Start
- Manual Seal Table Adjustment
- Proximity Sensor Switching for Impulse Seal Wires
- Anodized Aluminum Seal Head with Film Clamps
- Heavy Duty Welded Frame with Locking Casters

Options:

- Powered Film Unwind
(Suggested for rolls over 24"W)
- Adjustable Inverting Plow
- Roller Table Loading Infeed
- Electronic Seal Head w/ Push Button Sealing Cycle
- Heavy Product Upgrades
- Additional Seal Length (Consult Factory)

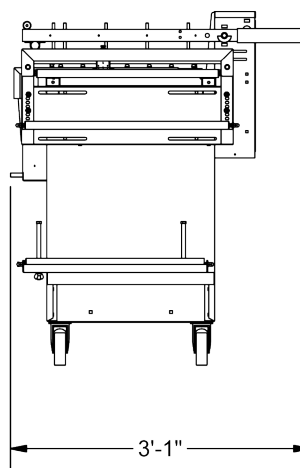
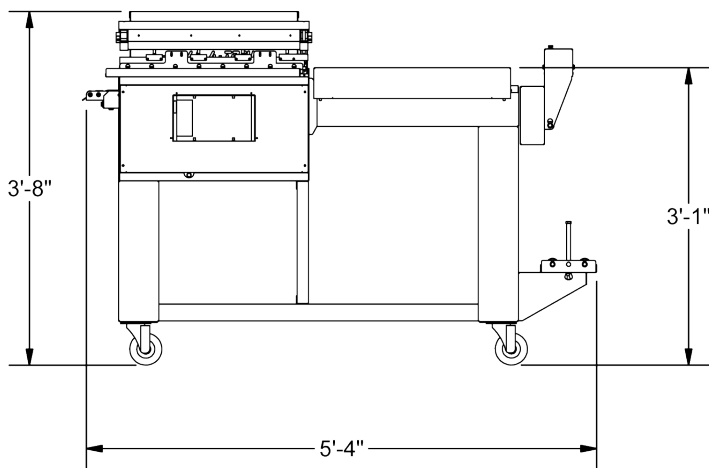

120 VAC
15 Amps
Dedicated Service

**BUILT FOR
SERIOUS
Performance**

Seal-A-Tron Corporation™ • 3815 S.E. Naef Road. • Portland, OR 97267 • Phone (503) 652-5200

Visit us on the Internet at: <http://www.seal-a-tron.com>