



SEAL-A-TRON

Shrink Packaging Equipment

SHRINK TECH SYSTEMS

PREMIUM MACHINERY
at a Reasonable Price!



MODEL
S-2330HK
SEMI-AUTOMATIC L-BAR SEALER

Seal Bar Dimensions: 23"W x 30"L x 8"H

Standard Features:

- Permanently Heated Hot Knife Seal Bar
- Powered Film Unwind w/Adjustable Inverting Plow
- Dual Mag-LOK Extra Strong Magnets
- Lightly Balanced Seal Head Pivot
- EZ-Perf Venting Pin Perf
- Product Discharge Conveyor with Soft Start
- Motorized Seal Table Adjustment
- Proximity Sensor Switching
- Heavy Duty Welded Frame with Locking Cast

Options:

- Scrap wind-up
- Roller Table Loading Infeed
- Electronic Seal Head w/Push Button Sealing Cycle
- Heavy Product Upgrades
- Additional Seal Length (Consult Factory)

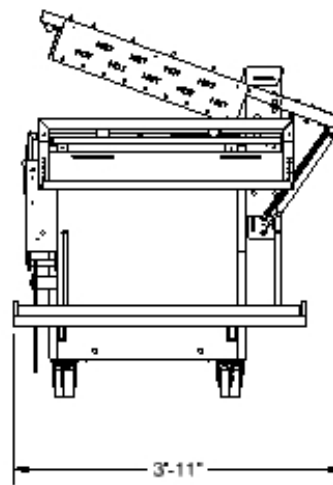
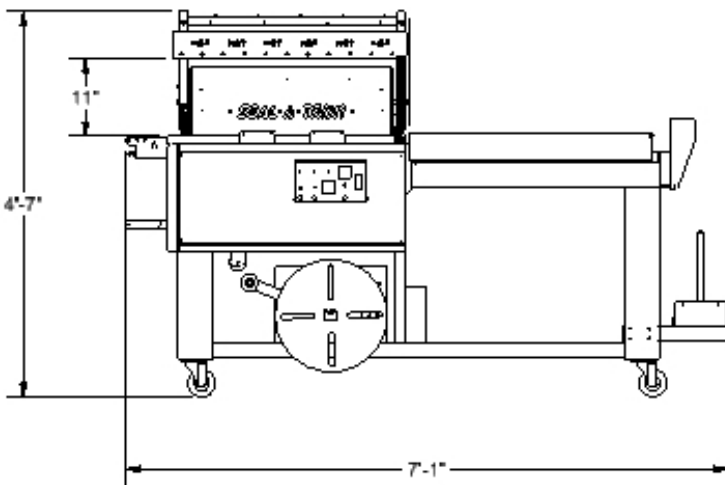

220 VAC Single Phase
30 Amp Service

BUILT FOR SERIOUS
Performance

Seal-A-Tron Corporation™ • 3815 S.E. Naef Road. • Portland, OR 97267 • Phone (503) 652-5200

Visit us on the Internet at: <http://www.seal-a-tron.com>