



SEAL·A·TRON

Shrink Packaging Equipment

SHRINK TECH SYSTEMS

**PREMIUM
MACHINERY**

*at a
Reasonable
Price!*



MODEL
S-3236HK

**SEMI-AUTOMATIC
L-BAR SEALER**

Seal Bar Dimensions:
32"W x 36"L x 8"H

Standard Features:

- Hot Knife Seal System
- Powered Film Unwind w/Adjustable Inverting Plow
- Dual Mag-LOK Extra Strong Magnets
- Lightly Balanced Seal Head Pivot
- EZ-Perf Venting Pin Perf
- Product Discharge Conveyor with Soft Start
- Motorized Seal Table Adjustment
- Proximity Sensor Switching for Impulse Seal Wires
- Anodized Aluminum Seal Head with Film Clamps
- Heavy Duty Welded Frame with Locking Casters

Options:

- Scrap wind-up
- Powered Film Unwind w/Adjustable Inverting Plow
- Roller Table Loading Infeed
- Electronic Seal Head w/ Push Button Sealing Cycle
- Heavy Product Upgrades
- Additional Seal Length (Consult Factory)

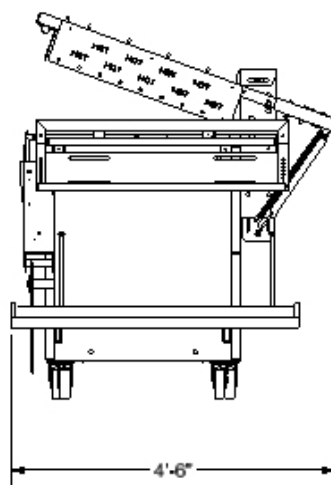
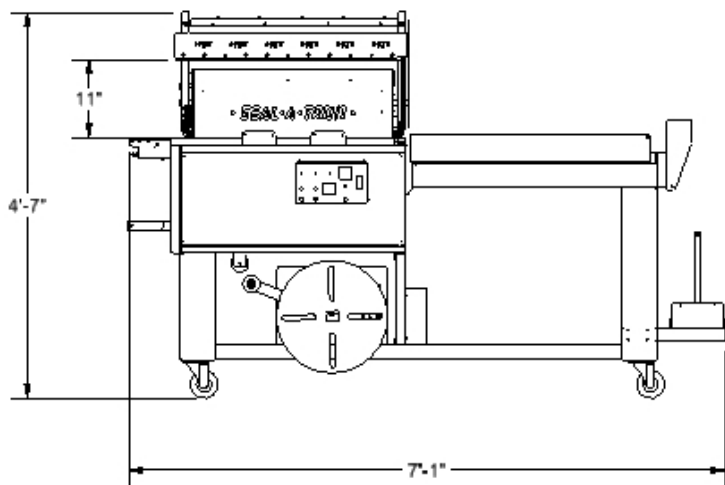

220 VAC Single Phase
30 Amps

**BUILT FOR
SERIOUS
Performance**

Seal-A-Tron Corporation™ • 3815 S.E. Naef Road. • Portland, OR 97267 • Phone (503) 652-5200

Visit us on the Internet at: <http://www.seal-a-tron.com>